

# T-MAC CYLINDERS, INC.

*HEAVY DUTY ALUMINUM CYLINDERS  
AND ACCESSORIES*



**HIGH QUALITY, DEPENDABLE, NFPA INTERCHANGEABLE  
CYLINDERS - MADE IN THE USA.**

9014 SWANSON DRIVE  
ROSCOE, IL 61073  
PHONE: 815-877-7090  
FAX: 815-877-7092  
E-MAIL: T-MAC\_CYLINDERS@MSN.COM



## **Superior quality, customer service, and on time deliveries.**

T-MAC CYLINDERS, INC., formed in 1996 to provide customers with these three key elements required in this industry today, and to expand on these in the 21st century.

**Quality.** 1. A degree or grade of excellence. At T-MAC CYLINDERS, INC., we strive for no less than an A+. The quality in our cylinders is in machining, performance, and aesthetics. Look at our design features. Honed aluminum tubing with closer I.D. tolerances than drawn tubing. Precision ground end caps for precise machining control, giving you true and square cylinder mounts to extend the life of your cylinder. Low friction seals for lower break away pressures and less running friction to extend seal life. These and the additional features listed herein, along with our stringent quality control process, means you as a valued customer receive T-MAC cylinders with quality second to none.

**Customer service and on time deliveries.** We at T-MAC CYLINDERS, INC. are in business to serve you. It's that simple. We know circumstances arise that require special attention. Flexibility is a must in this industry. If you the customer has a breakdown situation, or requires orders to be expedited due to your customers demands, we will do everything possible to get your product to you when you need it.

At T-MAC CYLINDERS, INC. this is our commitment. Not just words, but a way of life.

Tom McMahon  
President

## **Table of contents**

Standard specifications.....	Page 1
How to order.....	Page 1
Design features.....	Page 2-3
T1 series cylinders.....	Page 4-8
Cylinder accessories.....	Page 9
T2 series cylinders.....	Page 10-14
Technical data-rod selection.....	Page 15
-stop tube.....	Page 15
-weight chart.....	Page 15
Switch information.....	Page 16
Terms of Sale.....	Page 17

# SPECIFICATIONS AND ORDERING INFORMATION

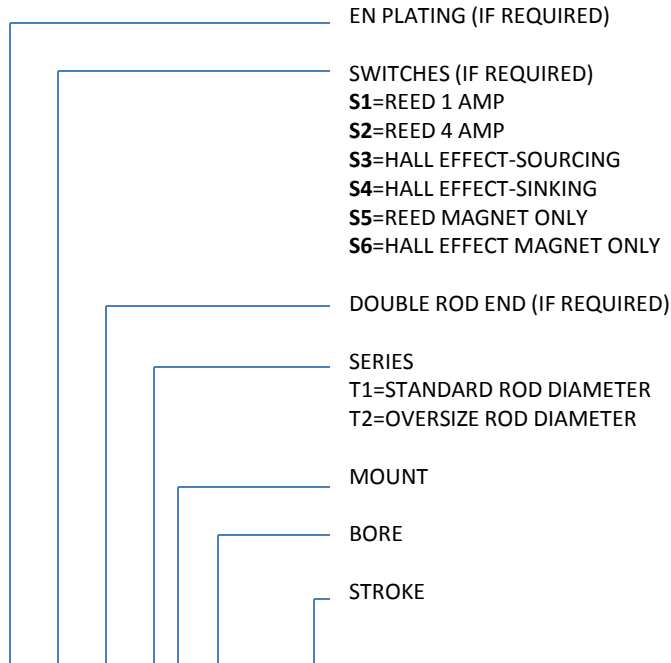

**E-S1-D-T1F-4.0X6.0-HC-2-BB-EE1-R-N-SP**

CUSHIONS (IF REQUIRED)

**N** = NON CUSHION  
**H** = CUSHION HEAD  
**C** = CUSHION CAP  
**HC** = CUSHION BOTH

ROD END STYLE

**1** = LARGE MALE (CC THD)  
**1F** = FULL DIA. MALE (FT THD)  
**2** = STANDARD MALE (KK THD)  
**4** = FEMALE (KK THD)  
**MOD** = NON STANDARD THREAD (SPECIFY)

BUMPERS (IF REQUIRED)

**BH** = BUMPER HEAD  
**BC** = BUMPER CAP  
**BB** = BUMPERS BOTH

PORT SIZE

**EE1** = STANDARD  
**EE2** = OVERSIZE

**R** = RETAINER PLATE (IF REQUIRED)

FOR HYDRAULIC SERVICE TO 500 PSI MAX

SEAL MATERIAL

**N** = NITRILE (STD)  
**V** = VITON – HIGH TEMP  
**LF** = LOW FRICTION

**SP** = SPECIAL MODIFICATIONS (PLEASE SPECIFY)

## STANDARD SPECIFICATIONS

- N.F.P.A. interchangeable.
- Pressure ratings:  
T1 and T2 series – 250 psi air/oil service.  
(HT and CT trunnion mounts 125 psi max.)
- Bore sizes - 1 ½", 2", 2 ½", 3 ¼", 4", 5", 6", 8" and 10".
- Rod diameters - Standard and one size over standard.
- Rod ends – Four available standards, specials upon request.
- Strokes – Any practical stroke length.
- Cushions – Optional at head, cap, or both ends.
- Single or double end rod configurations.
- 16 mounting styles to choose from.
- Temperature range -10 degrees F. to +225 degrees F.

## OPTIONAL FEATURES

- Viton seals for high temperature service.  
-10 degrees F. to +350 degrees F.
- Bumpers (noise reduction)  
Available at head end, cap end, or both ends of cylinder. Each bumper increases cylinder length by ¼". (Not available in viton material.)
- Adjustable stroke – Allows adjustment of the retracted position of the piston rod.
- Metallic rod scraper – Wipes harsh particles from rod to protect rod seal.
- End of stroke switches – Reed and hall effect available.
- Retainer plate – For hydraulic service above 250 psi up to 500 psi max.  
500 psi non-shock on 1 ½" thru 6" bores.  
350 psi non-shock on 8" and 10" bores.  
(Note: 125 psi max. non-shock for head and cap trunnion mounts.)
- Air/oil piston – Allows cylinder to operate on air while controlling travel with oil for smooth operation.
- Stainless steel piston rods and tie rods.
- Stop tubes. (see page 15 for details.)
- Electroless nickel plating for corrosive environments.

## SPECIALTY CYLINDERS

- Duplex cylinders - Essentially doubles cylinder force.
- Three position cylinders.
- Back to back cylinders.
- Spring extend or spring retract cylinders.
- Stainless steel cylinders.
- Specials welcome. Call for quotations.

**Head and Cap** – Billet aluminum blocks Precision ground on all six sides for true And square mounting surfaces. Black Anodized for corrosion resistance.

**NPTF Ports** – One size under industry Standard saves money in fittings, hose, And air consumption. One size over Standard available.

**Tube seals** – O-ring design For positive sealing.

**Piston** – One piece of solid aluminum alloy Threaded to piston rod. Relief grooves on Both sides provide fast breakaway. Center Groove machined for magnetic piston option, Providing field update capabilities. Piston is Torqued to rod in conjunction with an anaerobic Adhesive for positive locking, then staked for a Secure connection.

**Piston Seals** – Lip type pressure energized and Wear compensating for positive sealing at all Rated pressures. Seals are internally lubricated For non lube service, providing low friction and Long service life.

**Tube** – Hard coat anodized aluminum for Superior wear resistance and long seal life.

**Tie Rods** – Pre-stressed high strength steel for maximum fatigue resistance. Black oxide finish for corrosion resistance.

**Cushions** – Designed to be as long as possible, Allowing more time to decelerate load. Longer Cushion time means less fatigue on the cylinder, thus increasing cylinder life.

**Cushion Seals** – Self centering, full floating design. Seal acts as both cushion seal and check valve, Providing effective cushion and fast breakaway. Molded from internally lubricated urethane.

**Rod Seal** – Lip type pressure energized and Wear compensating for positive sealing at All rated pressures.

**Sleeve Nut Design** – Allows quick and easy Bolt on option for flange and angle mounts, Or can be used as a mount itself. Available On both T1 and T2 series cylinders, except T2 1 1/2" bore.

**Rod Wiper** – one piece urethane, snap in type rod wiper/scrapper.

**Piston Rod** – Made from 75,000 psi yield Material, polished and hard chrome plated For long seal life. Style #2 rod ends are Studded on 5/8" & 1" rods for maximum Strength.

**Retaining Ring** – Pre-hardened spring tempered flat wire retaining ring. Designed to retain rod bearing well above rated cylinder pressure. Allows bearing to "float" slightly in head pocket to better align cylinder. Easy removal of bearing without disassembling cylinder.

**Rod Bearing** – Long iron bearing for maximum rod support and cylinder Life. Removable without disassembling Cylinder. Lube groove between rod seal And wiper for extended life.

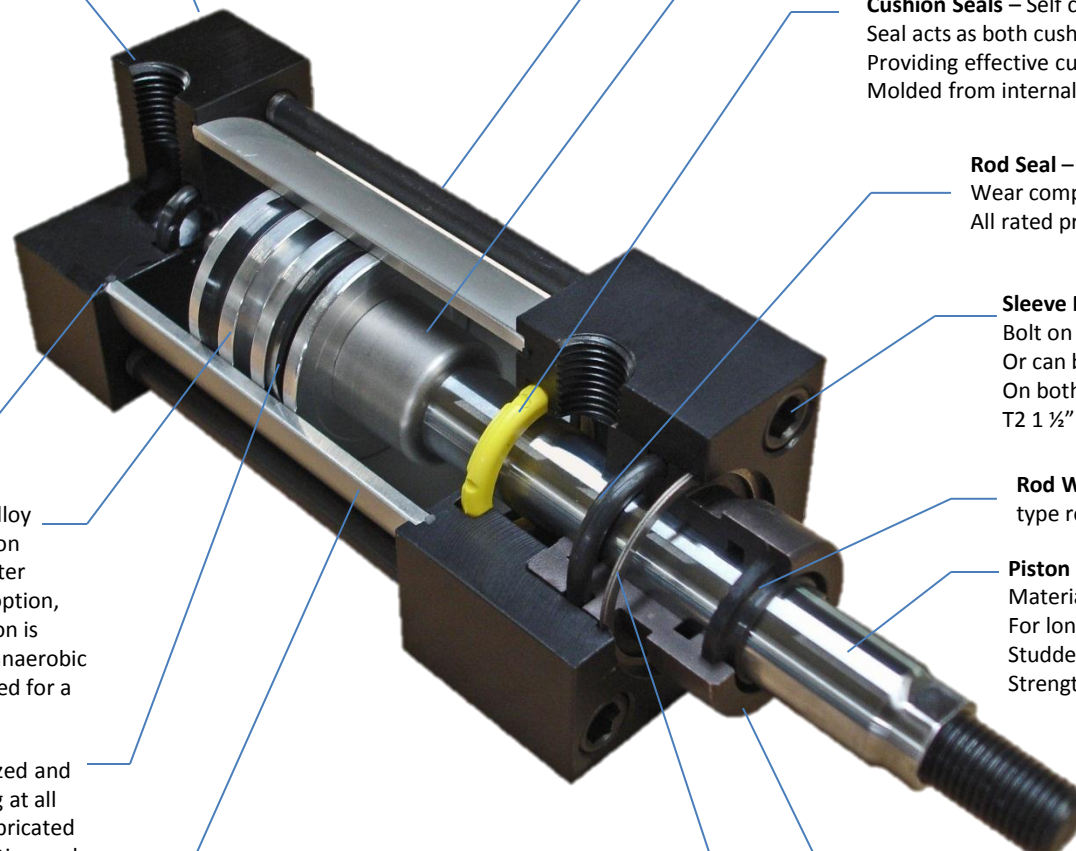

# T1 SERIES CYLINDERS - STANDARD ROD DIAMETER

## MODEL T1 - BASIC CYLINDER

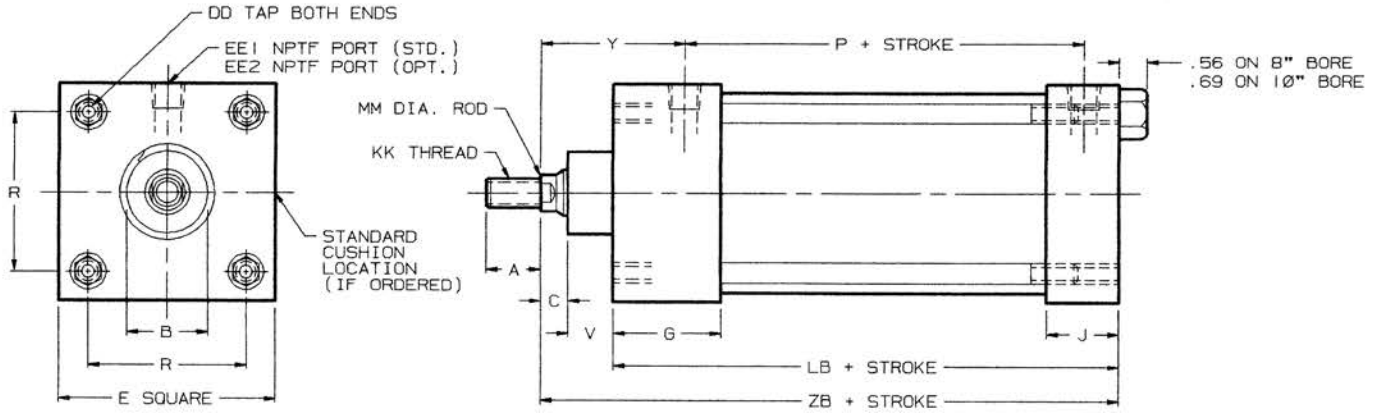

BORE	A	B	C	DD	E	EE1	EE2	G	J	KK	LB	MM	P	R	V	Y	ZB
1 1/2	3/4	1 1/8	3/8	1/4-28	2	1/4	3/8	1 1/2	1	7/16-20	3 5/8	5/8	2 1/4	1.43	5/8	1 29/32	4 5/8
2	3/4	1 1/8	3/8	5/16-24	2 1/2	1/4	3/8	1 1/2	1	7/16-20	3 5/8	5/8	2 1/4	1.84	5/8	1 29/32	4 5/8
2 1/2	3/4	1 1/8	3/8	5/16-24	3	1/4	3/8	1 1/2	1	7/16-20	3 3/4	5/8	2 3/8	2.19	5/8	1 29/32	4 3/4
3 1/4	1 1/8	1 1/2	1/2	3/8-24	3 3/4	3/8	1/2	1 3/4	1 1/4	3/4-16	4 1/4	1	2 5/8	2.76	7/8	2 7/16	5 5/8
4	1 1/8	1 1/2	1/2	3/8-24	4 1/2	3/8	1/2	1 3/4	1 1/4	3/4-16	4 1/4	1	2 5/8	3.32	7/8	2 7/16	5 5/8
5	1 1/8	1 1/2	1/2	1/2-20	5 1/2	3/8	1/2	1 3/4	1 1/2	3/4-16	4 1/2	1	2 7/8	4.10	7/8	2 7/16	5 7/8
6	1 5/8	2	5/8	1/2-20	6 1/2	1/2	3/4	2	1 1/2	1-14	5	1 3/8	3 1/8	4.88	1	2 13/16	6 5/8
8	1 5/8	2	5/8	5/8-18	8 1/2	1/2	3/4	2	1 1/2	1-14	5 1/8	1 3/8	3 1/4	6.43	1	2 13/16	6 3/4
10	2	2 3/8	3/4	3/4-16	10 5/8	3/4	1	2 1/4	2	1 1/4-12	6 3/8	1 3/4	4 1/8	7.96	3/8**	3 1/8	8 1/4

\*\* 10" BORE HAS A CIRCULAR RETAINER TO RETAIN BEARING. SEE 10" BORE T1FH MOUNT FOR DIMENSIONS.

## MODEL DT1 - DOUBLE ROD END

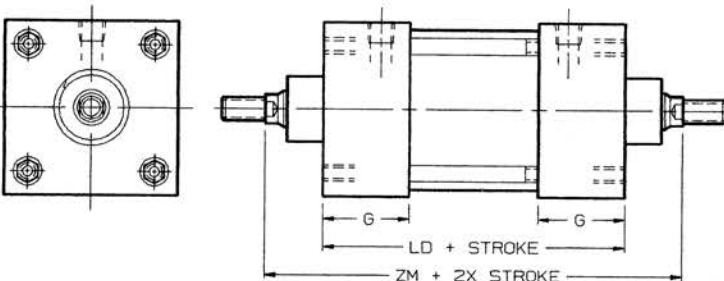

BORE	G	LD	ZM
1 1/2	1 1/2	4 1/8	6 1/8
2	1 1/2	4 1/8	6 1/8
2 1/2	1 1/2	4 1/4	6 1/4
3 1/4	1 3/4	4 3/4	7 1/2
4	1 3/4	4 3/4	7 1/2
5	1 3/4	4 3/4	7 1/2
6	2	5 1/2	8 3/4
8	2	5 5/8	8 7/8
10	2 1/4	6 5/8	10 3/8

ON DT1B 5" BORE ONLY "SN" DIMENSION WILL DECREASE BY 1/4".

ON DT1L MOUNT ADD 1/4" TO "SS" DIMENSION ON 5" BORE, AND 1/2" TO ALL OTHER BORES.

## ROD END STYLES

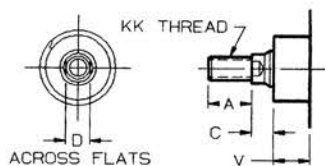

**STYLE 2  
STANDARD**

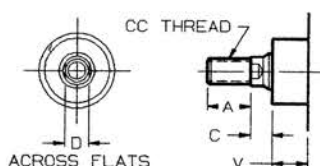

**STYLE 1  
LARGE MALE THD.**

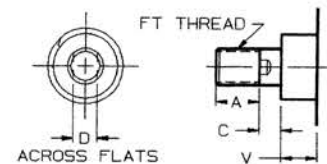

**STYLE 1F  
FULL DIA. THD.**

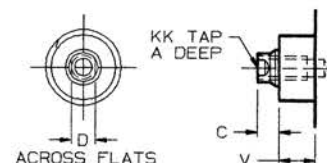

**STYLE 4  
FEMALE THD.**

STYLE #2 IS STUDDED ON 5/8 AND 1" DIAMETER RODS.

ROD DIA.	A	C	D	V	CC	FT	KK
5/8	3/4	3/8	1/2	5/8	1/2-20	5/8-18	7/16-20
1	1 1/8	1/2	7/8	7/8	7/8-14	1-14	3/4-16
1 3/8	1 5/8	5/8	1 3/16	1	1 1/4-12	1 3/8-12	1-14
1 3/4	2	3/4	1 1/2	3/8**	1 1/2-12	1 3/4-12	1 1/4-12

# T1 SERIES CYLINDERS - STANDARD ROD DIAMETER

## MODEL T1F - FRONT FLANGE MOUNT (NFPA MF1)

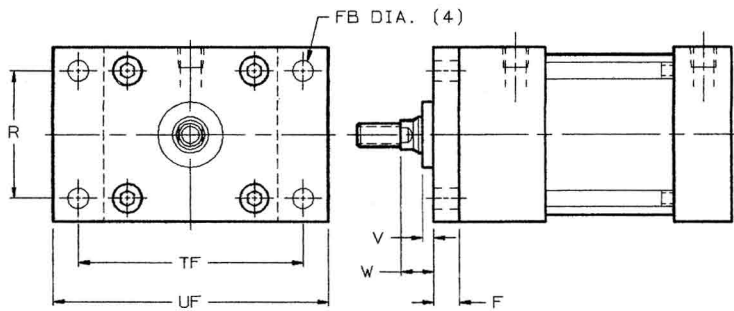

BORE	F	FB	R	TF	UF	V	W
1 1/2	3/8	5/16	1.43	2 3/4	3 3/8	1/4	5/8
2	3/8	3/8	1.84	3 3/8	4 1/8	1/4	5/8
2 1/2	3/8	3/8	2.19	3 7/8	4 5/8	1/4	5/8
3 1/4	5/8	7/16	2.76	4 11/16	5 1/2	1/4	3/4
4	5/8	7/16	3.32	5 7/16	6 1/4	1/4	3/4
5	5/8	9/16	4.1	6 5/8	7 5/8	1/4	3/4
6	3/4	9/16	4.88	7 5/8	8 5/8	1/4	7/8

## MODEL T1R - REAR FLANGE MOUNT (NFPA MF2)

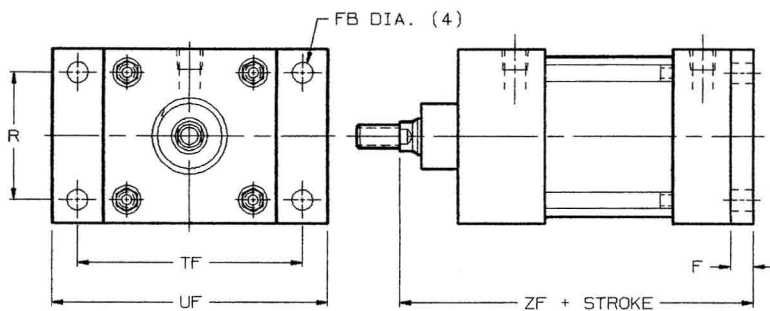

BORE	F	FB	R	TF	UF	ZF
1 1/2	3/8	5/16	1.43	2 3/4	3 3/8	5
2	3/8	3/8	1.84	3 3/8	4 1/8	5
2 1/2	3/8	3/8	2.19	3 7/8	4 5/8	5 1/8
3 1/4	5/8	7/16	2.76	4 11/16	5 1/2	6 1/4
4	5/8	7/16	3.32	5 7/16	6 1/4	6 1/4
5	5/8	9/16	4.1	6 5/8	7 5/8	6 1/2
6	3/4	9/16	4.88	7 5/8	8 5/8	7 3/8

## MODEL T1HF - 8" BORE HEAD FLANGE MOUNT (NFPA ME3)

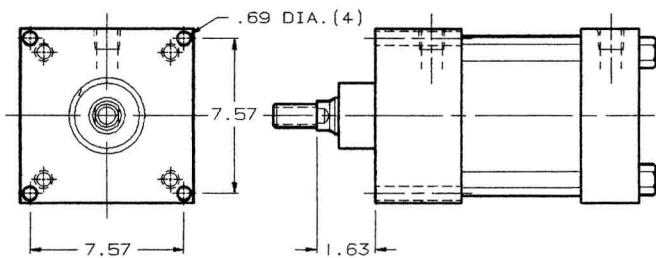

## MODEL T1CF - 8" BORE CAP FLANGE MOUNT (NFPA ME4)

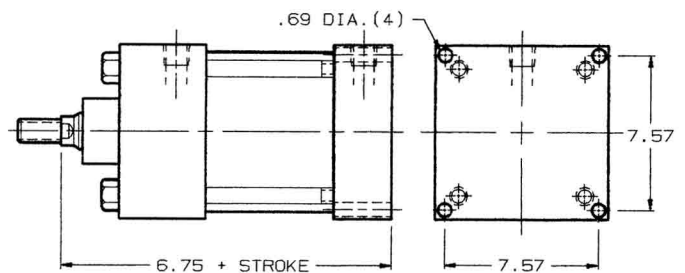

## MODEL T1HF - 10" BORE HEAD FLANGE MOUNT (NFPA ME3)

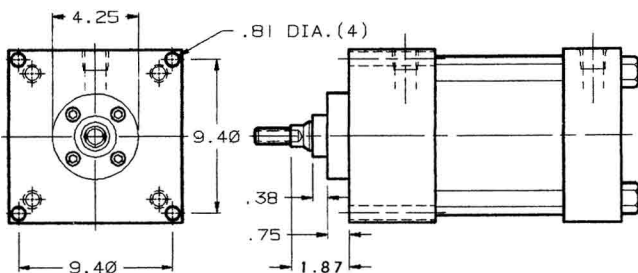

## MODEL T1CF - 10" BORE CAP FLANGE MOUNT (NFPA ME4)

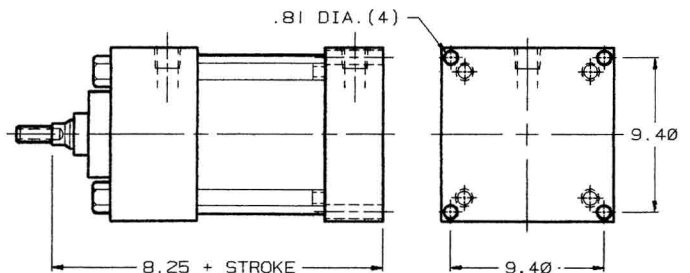

# T1 SERIES CYLINDERS - STANDARD ROD DIAMETER

## MODEL T1B - BOTTOM TAP MOUNT (NFPA MS4)

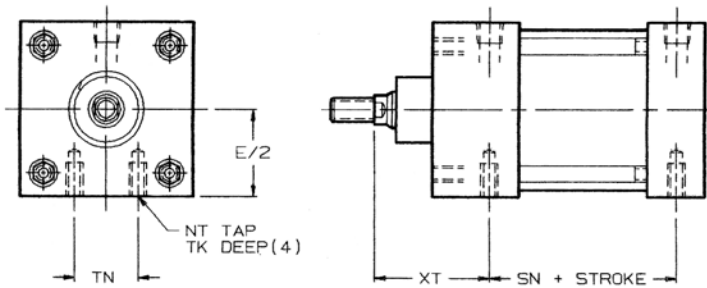

BORE	NT	SN	TK	TN	XT
1 1/2	1/4-20	2 1/4	3/8	5/8	1 15/16
2	5/16-18	2 1/4	1/2	7/8	1 15/16
2 1/2	3/8-16	2 3/8	5/8	1 1/4	1 15/16
3 1/4	1/2-13	2 5/8	3/4	1 1/2	2 7/16
4	1/2-13	2 5/8	3/4	2 1/16	2 7/16
5	5/8-11	2 7/8	1	2 11/16	2 7/16
6	3/4-10	3 1/8	1 1/8	3 1/4	2 13/16
8	3/4-10	3 1/4	1 1/8	4 1/2	2 13/16

## MODEL T1C - CLEVIS MOUNT (NFPA MP1)

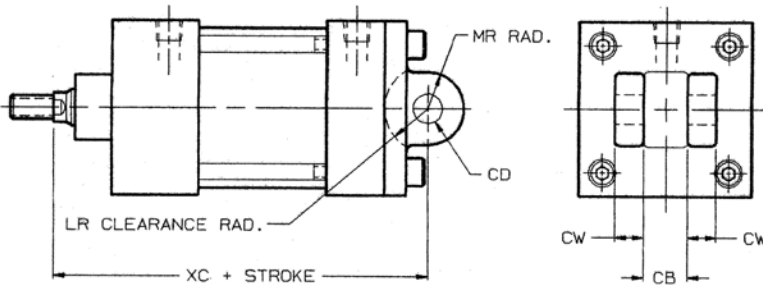

BORE	CB	CD	CW	LR	MR	XC
1 1/2	3/4	1/2	3/8	3/4	5/8	5 3/8
2	3/4	1/2	1/2	3/4	5/8	5 3/8
2 1/2	3/4	1/2	1/2	3/4	5/8	5 1/2
3 1/4	1 1/4	3/4	3/4	1 1/4	7/8	6 7/8
4	1 1/4	3/4	3/4	1 1/4	7/8	6 7/8
5	1 1/4	3/4	3/4	1 1/4	7/8	7 1/8
6	1 1/2	1	1	1 1/2	1 1/8	8 1/8
8	1 1/2	1	3/4	1 1/2	1	8 1/4

## MODEL T1DC - DETACHABLE CLEVIS MOUNT (NFPA MP2)

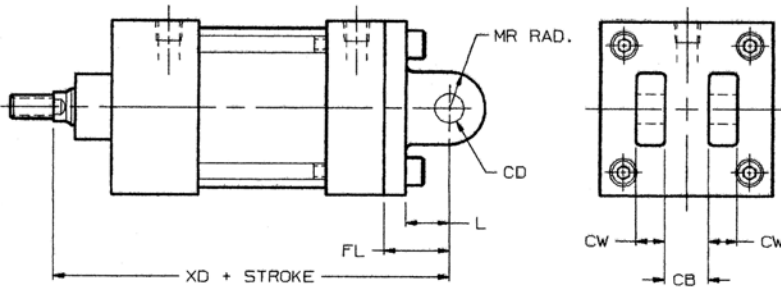

BORE	CB	CD	CW	FL	L	MR	XD
1 1/2	3/4	1/2	3/8	1 1/8	3/4	5/8	5 3/4
2	3/4	1/2	1/2	1 1/8	3/4	5/8	5 3/4
2 1/2	3/4	1/2	1/2	1 1/8	3/4	5/8	5 7/8
3 1/4	1 1/4	3/4	3/4	1 7/8	1 1/4	7/8	7 1/2
4	1 1/4	3/4	3/4	1 7/8	1 1/4	7/8	7 1/2
5	1 1/4	3/4	3/4	1 7/8	1 1/4	7/8	7 3/4
6	1 1/2	1	1	2 1/4	1 1/2	1 1/8	8 7/8

## MODEL T1DE - DETACHABLE EYE MOUNT (NFPA MP4)

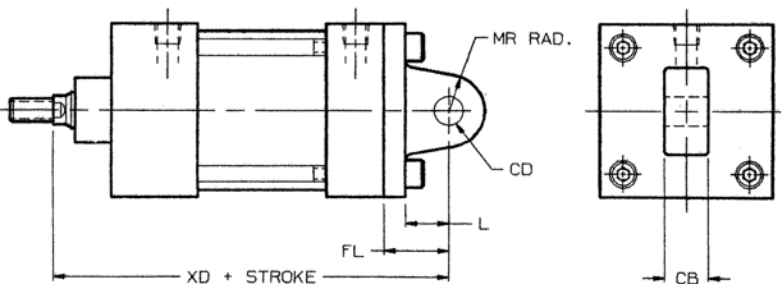

BORE	CB	CD	FL	L	MR	XD
1 1/2	3/4	1/2	1 1/8	3/4	5/8	5 3/4
2	3/4	1/2	1 1/8	3/4	5/8	5 3/4
2 1/2	3/4	1/2	1 1/8	3/4	5/8	5 7/8
3 1/4	1 1/4	3/4	1 7/8	1 1/4	7/8	7 1/2
4	1 1/4	3/4	1 7/8	1 1/4	7/8	7 1/2

# T1 SERIES CYLINDERS - STANDARD ROD DIAMETER

## MODEL T1HT - HEAD TRUNNION MOUNT (NFPA MT1)

TRUNNION PINS ARE HARD CHROME PLATED STEEL.  
MAXIMUM PRESSURE RATING 125 PSI.

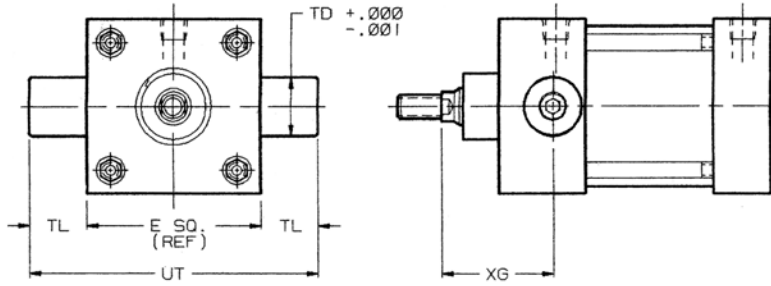

BORE	E	TD	TL	UT	XG
1 1/2	2	1	1	4	1 15/16
2	2 1/2	1	1	4 1/2	1 15/16
2 1/2	3	1	1	5	1 15/16
3 1/4	3 3/4	1	1	5 3/4	2 7/16
4	4 1/2	1	1	6 1/2	2 7/16
5	5 1/2	1	1	7 1/2	2 7/16
6	6 1/2	1 3/8	1 3/8	9 1/4	2 13/16
8	8 1/2	1 3/8	1 3/8	11 1/4	2 13/16

## MODEL T1CT - CAP TRUNNION MOUNT (NFPA MT2)

TRUNNION PINS ARE HARD CHROME PLATED STEEL.  
MAXIMUM PRESSURE RATING 125 PSI.

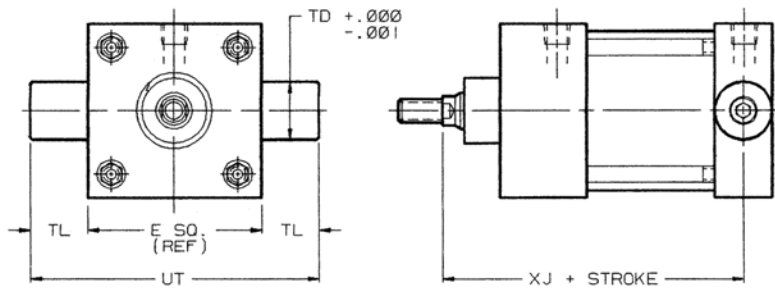

BORE	E	TD	TL	UT	XJ
1 1/2	2	1	1	4	4 1/8
2	2 1/2	1	1	4 1/2	4 1/8
2 1/2	3	1	1	5	4 1/4
3 1/4	3 3/4	1	1	5 3/4	5
4	4 1/2	1	1	6 1/2	5
5	5 1/2	1	1	7 1/2	5 1/4
6	6 1/2	1 3/8	1 3/8	9 1/4	5 7/8
8	8 1/2	1 3/8	1 3/8	11 1/4	6

## MODEL T1IT - INTERMEDIATE TRUNNION MOUNT (NFPA MT4)

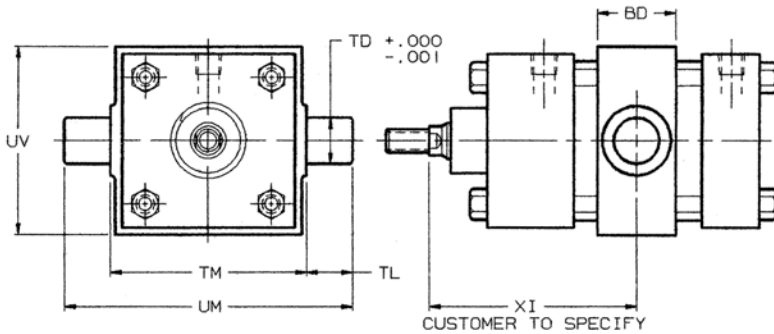

BORE	BD	TD	TL	TM	UM	UV
1 1/2	1 1/4	1	1	2 1/2	4 1/2	2 1/2
2	1 1/2	1	1	3	5	3
2 1/2	1 1/2	1	1	3 1/2	5 1/2	3 1/2
3 1/4	2	1	1	4 1/2	6 1/2	4 1/4
4	2	1	1	5 1/4	7 1/4	5
5	2	1	1	6 1/4	8 1/4	6
6	2 1/2	1 3/8	1 3/8	7 5/8	10 3/8	7

## MODEL T1A - ANGLE MOUNT (NFPA MS1)

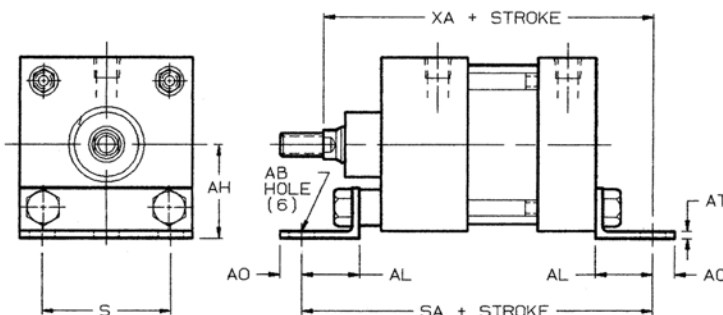

BORE	AB	AH	AL	AO	AT	S	SA	XA
1 1/2	7/16	1 3/16	1	3/8	1/8	1 1/4	6	5 5/8
2	7/16	1 7/16	1	3/8	1/8	1 3/4	6	5 5/8
2 1/2	7/16	1 5/8	1	3/8	1/8	2 1/4	6 1/8	5 3/4
3 1/4	9/16	1 15/16	1 1/4	1/2	3/16	2 3/4	7 3/8	6 7/8
4	9/16	2 1/4	1 1/4	1/2	3/16	3 1/2	7 3/8	6 7/8
5	11/16	2 3/4	1 3/8	5/8	3/16	4 1/4	7 7/8	7 1/4
6	13/16	3 1/4	1 3/8	5/8	1/4	5 1/4	8 1/2	8



# T1 SERIES CYLINDERS - STANDARD ROD DIAMETER

## MODEL T1L - SIDE LUG MOUNT (NFPA MS2)

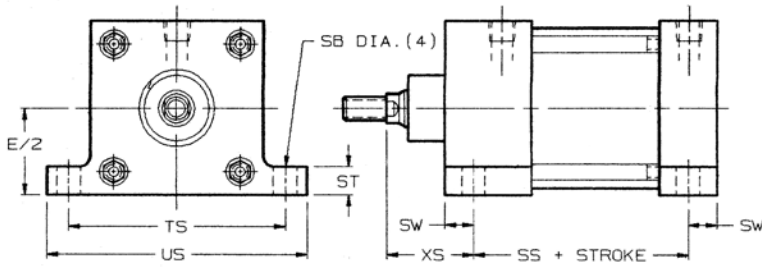

BORE	SB	SS	ST	SW	TS	US	XS
1 1/2	13/32	2 7/8	1/2	3/8	2 3/4	3 1/2	1 3/8
2	13/32	2 7/8	1/2	3/8	3 1/4	4	1 3/8
2 1/2	13/32	3	1/2	3/8	3 3/4	4 1/2	1 3/8
3 1/4	17/32	3 1/4	3/4	1/2	4 3/4	5 3/4	1 7/8
4	17/32	3 1/4	3/4	1/2	5 1/2	6 1/2	1 7/8
5	25/32	3 1/8	1	11/16	6 7/8	8 1/4	2 1/16
6	25/32	3 5/8	1	11/16	7 7/8	9 1/4	2 5/16
8	25/32	3 3/4	1	11/16	9 7/8	11 1/4	2 5/16

## MODEL T1M - EXTENDED TIE ROD MOUNT HEAD END (NFPA MX3)

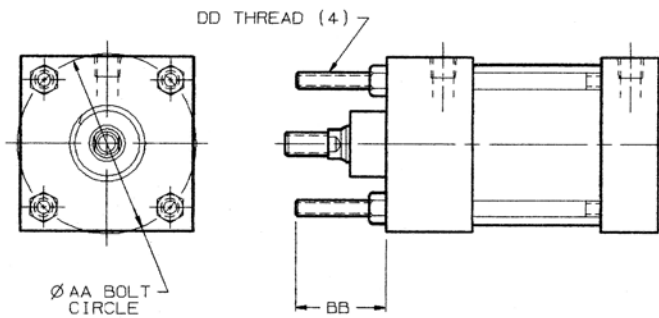

BORE	AA	BB	DD
1 1/2	2.02	1	1/4-28
2	2.60	1 1/8	5/16-24
2 1/2	3.10	1 1/8	5/16-24
3 1/4	3.90	1 3/8	3/8-24
4	4.70	1 3/8	3/8-24
5	5.80	1 13/16	1/2-20
6	6.90	1 13/16	1/2-20
8	9.10	2 5/16	5/8-18

## MODEL T1N - EXTENDED TIE ROD MOUNT CAP END (NFPA MX2)

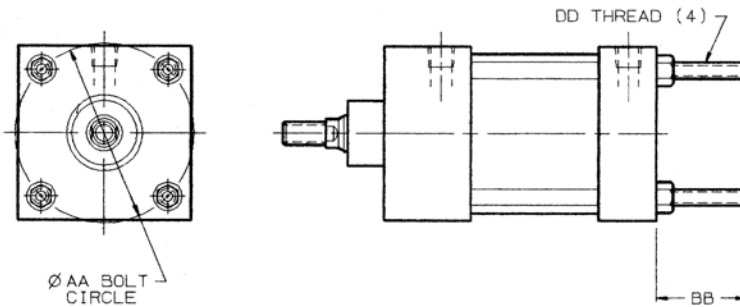

BORE	AA	BB	DD
1 1/2	2.02	1	1/4-28
2	2.60	1 1/8	5/16-24
2 1/2	3.10	1 1/8	5/16-24
3 1/4	3.90	1 3/8	3/8-24
4	4.70	1 3/8	3/8-24
5	5.80	1 13/16	1/2-20
6	6.90	1 13/16	1/2-20
8	9.10	2 5/16	5/8-18

## MODEL T1P - EXTENDED TIE ROD MOUNT BOTH ENDS (NFPA MX1)

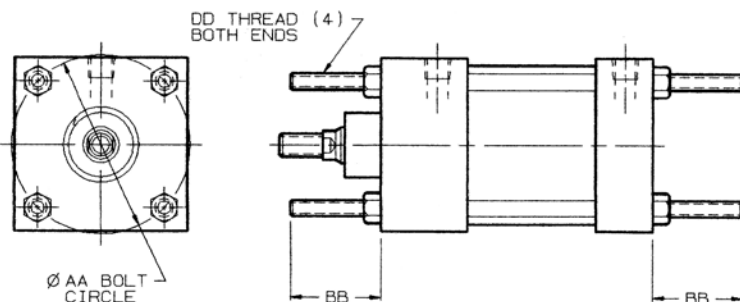

BORE	AA	BB	DD
1 1/2	2.02	1	1/4-28
2	2.60	1 1/8	5/16-24
2 1/2	3.10	1 1/8	5/16-24
3 1/4	3.90	1 3/8	3/8-24
4	4.70	1 3/8	3/8-24
5	5.80	1 13/16	1/2-20
6	6.90	1 13/16	1/2-20
8	9.10	2 5/16	5/8-18

# NFPA ACCESSORIES

## ROD CLEVIS

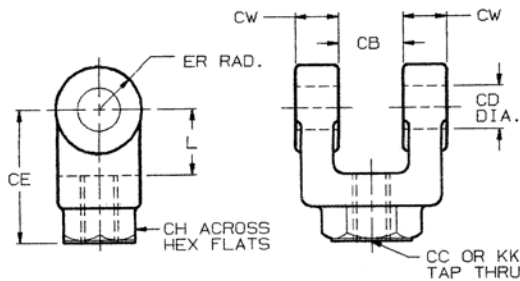

PART NO.	CB	CC	CD	CE	CH	CW	ER	KK	L
T1-820-63	3/4	---	1/2	1 1/2	1	1/2	1/2	7/16-20	3/4
T1-820-63C	3/4	1/2-20	1/2	1 1/2	1	1/2	1/2	---	3/4
T1-820-100	1 1/4	---	3/4	2 3/8	1 1/4	5/8	3/4	3/4-16	1 1/4
T1-820-138	1 1/2	---	1	3 1/8	1 1/2	3/4	1	1-14	1 1/2
T1-820-138C	1 1/2	1 1/4-12	1	3 1/8	1 1/2	3/4	1	---	1 1/2
T1-820-175	2	---	1 3/8	4 1/8	2	1	1 3/8	1 1/4-12	2 1/8
T1-820-200	2 1/2	---	1 3/4	4 1/2	2 3/8	1 1/4	1 3/4	1 1/2-12	2 1/4

## ROD EYE

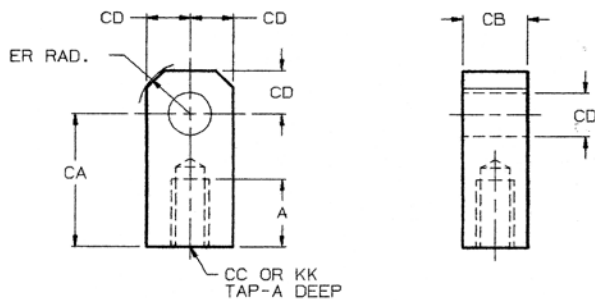

PART NO.	A	CA	CB	CC	CD	ER	KK
T1-821-63	3/4	1 1/2	3/4	---	1/2	9/16	7/16-20
T1-821-63C	3/4	1 1/2	3/4	1/2-20	1/2	9/16	---
T1-821-100	1 1/8	2 1/16	1 1/4	---	3/4	15/16	3/4-16
T1-821-138	1 5/8	2 13/16	1 1/2	---	1	1 1/8	1-14
T1-821-138C	2	2 13/16	1 1/2	1 1/4-12	1	1 1/8	---
T1-821-175	2	3 7/16	2	---	1 3/8	1 3/8	1 1/4-12
T1-821-200	2 1/4	4	2 1/2	---	1 3/4	1 3/4	1 1/2-12

## EYE BRACKET

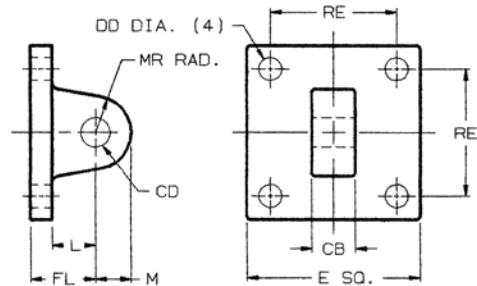

PART NO.	CB	CD	DD	E	FL	L	M	RE
T1-822-63	3/4	1/2	13/32	2 1/2	1 1/8	3/4	1/2	1.63
T1-822-100	1 1/4	3/4	17/32	3 1/2	1 7/8	1 1/4	3/4	2.56
T1-822-138	1 1/2	1	21/32	4 1/2	2 1/4	1 1/2	1	3.25
T1-822-175	2	1 3/8	21/32	5	3	2 1/8	1 3/8	3.81
T1-822-200	2 1/2	1 3/4	29/32	6 1/2	3 1/8	2 1/4	1 3/4	4.95

## CLEVIS BRACKET

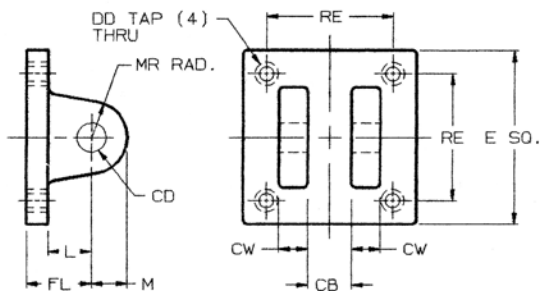

PART NO.	CB	CD	CW	DD	E	FL	L	M	RE
T1-823-63	3/4	1/2	1/2	3/8-24	2 1/2	1 1/8	3/4	1/2	1.63
T1-823-100	1 1/4	3/4	5/8	1/2-20	3 1/2	1 7/8	1 1/4	3/4	2.56
T1-823-138	1 1/2	1	3/4	5/8-18	4 1/2	2 1/4	1 1/2	1	3.25
T1-823-175	2	1 3/8	1	5/8-18	5	3	2 1/8	1 3/8	3.81
T1-823-200	2 1/2	1 3/4	1 1/4	7/8-14	6 1/2	3 1/8	2 1/4	1 3/4	4.95

## PIVOT PIN

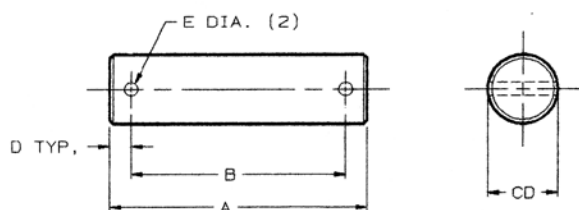

PART NO.	A	B	CD	D	E
T1-824-63	2 9/32	1 15/16	1/2	0.17	0.106
T1-824-100	3 3/32	2 23/32	3/4	0.19	0.140
T1-824-138	3 19/32	3 7/32	1	0.19	0.140
T1-824-175	4 21/32	4 1/4	1 3/8	0.20	0.173
T1-824-200	5 21/32	5 1/4	1 3/4	0.20	0.173

# T2 SERIES CYLINDERS - OVERSIZE ROD DIAMETER

## MODEL T2 - BASIC CYLINDER

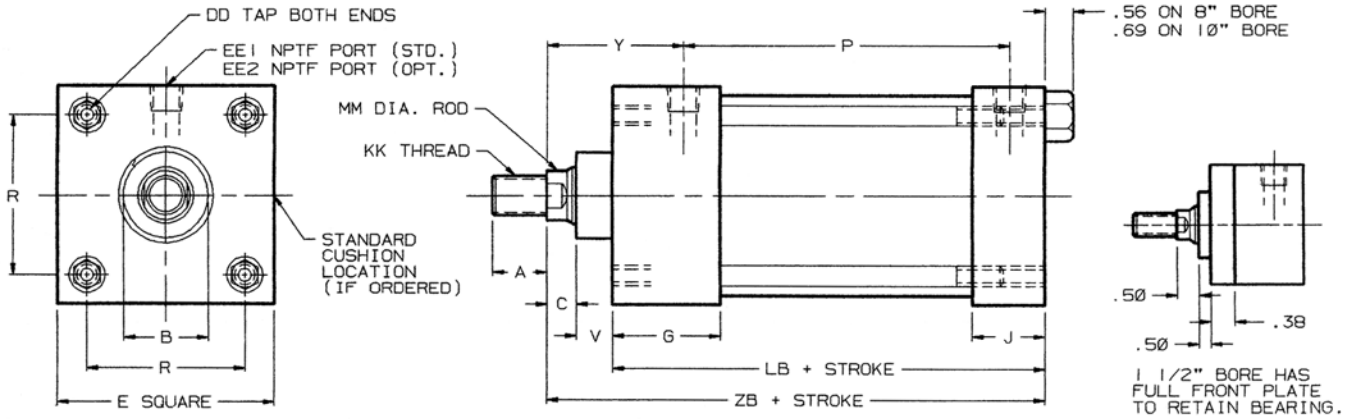

BORE	A	B	C	DD	E	EE1	EE2	G	J	KK	LB	MM	P	R	V	Y	ZB
1 1/2	1 1/8	1 5/16	1/2	1/4-28	2	1/4	3/8	1 1/2	1	3/4-16	3 5/8	1	2 1/4	1.43	1/2++	2 9/32	5
2	1 1/8	1 1/2	1/2	5/16-24	2 1/2	1/4	3/8	1 1/2	1	3/4-16	3 5/8	1	2 1/4	1.84	7/8	2 9/32	5
2 1/2	1 1/8	1 1/2	1/2	5/16-24	3	1/4	3/8	1 1/2	1	3/4-16	3 3/4	1	2 3/8	2.19	7/8	2 9/32	5 1/8
3 1/4	1 5/8	2	5/8	3/8-24	3 3/4	3/8	1/2	1 3/4	1 1/4	1-14	4 1/4	1 3/8	2 5/8	2.76	1	2 11/16	5 7/8
4	1 5/8	2	5/8	3/8-24	4 1/2	3/8	1/2	1 3/4	1 1/4	1-14	4 1/4	1 3/8	2 5/8	3.32	1	2 11/16	5 7/8
5	1 5/8	2	5/8	1/2-20	5 1/2	3/8	1/2	1 3/4	1 1/2	1-14	4 1/2	1 3/8	2 7/8	4.10	1	2 11/16	6 1/8
6	2	2 3/8	1	1/2-20	6 1/2	1/2	3/4	2	1 1/2	1 1/4-12	5	1 3/4	3 1/8	4.88	7/8	3 1/16	6 7/8
8	2	2 3/8	3/4	5/8-18	8 1/2	1/2	3/4	2	1 1/2	1 1/4-12	5 1/8	1 3/4	3 1/4	6.43	3/8**	3 1/16	7
10	2 1/4	2 5/8	7/8	3/4-16	10 5/8	3/4	1	2 1/4	2	1 1/2-12	6 3/8	2	4 1/8	7.96	3/8**	3 1/4	8 3/8

++ 1 1/2" BORE HAS FULL FRONT PLATE TO RETAIN BEARING. SEE AUXILIARY VIEW ABOVE RIGHT.

\*\* 8 AND 10" BORES HAVE A CIRCULAR RETAINER TO RETAIN BEARING. SEE 8 AND 10" BORE T2FH MOUNTS FOR DIMENSIONS.

## MODEL DT2 - DOUBLE ROD END

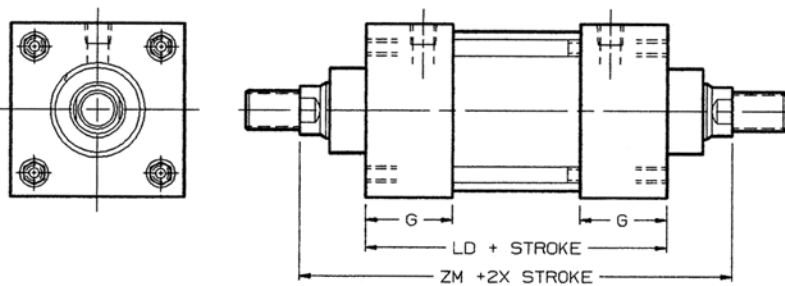

BORE	G	LD	ZM
1 1/2	1 1/2	4 7/8 ++	6 7/8
2	1 1/2	4 1/8	6 1/8
2 1/2	1 1/2	4 1/4	6 1/4
3 1/4	1 3/4	4 3/4	7 1/2
4	1 3/4	4 3/4	7 1/2
5	1 3/4	4 3/4	7 1/2
6	2	5 1/2	8 3/4
8	2	5 5/8	8 7/8
10	2 1/4	6 5/8	10 3/8

++ ON 1 1/2" BORE "LD" DIMENSION INCLUDES FULL FRONT PLATES.  
 ON DT1B 5" BORE ONLY "SN" DIMENSION WILL DECREASE BY 1/4".  
 ON DT1L MOUNT ADD 1/4" TO "SS" DIMENSION ON 5" BORE, AND  
 1/2" TO ALL OTHER BORES.

## ROD END STYLES

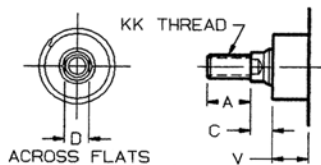

STYLE #2 IS STUDDED ON 1" DIAMETER ROD.

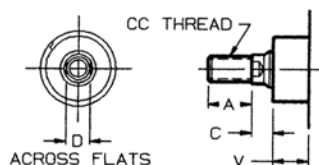

ROD DIA.	A	C	D	V	CC	FT	KK
1	1 1/8	1/2	7/8	7/8++	7/8-14	1-14	3/4-16
1 3/8	1 5/8	5/8	1 3/16	1	1 1/4-12	1 3/8-12	1-14
1 3/4	2	3/4	1 1/2	1 1/8	1 1/2-12	1 3/4-12	1 1/4-12
2	2 1/4	7/8	1 3/4	3/8**	1 3/4-12	2-12	1 1/2-12

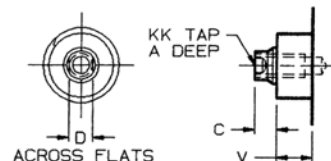
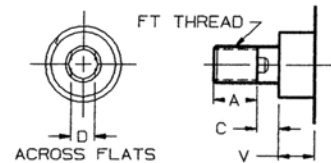

# T2 SERIES CYLINDERS - OVERSIZE ROD DIAMETER

## MODEL T2F - FRONT FLANGE MOUNT (NFPA MF1)

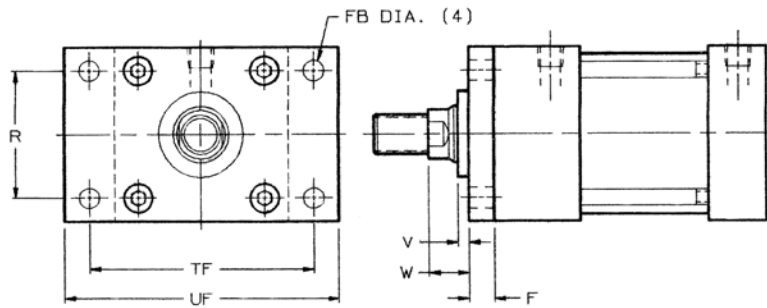

BORE	F	FB	R	TF	UF	V	W
1 1/2	3/8	5/16	1.43	2 3/4	3 3/8	1/2	1
2	3/8	3/8	1.84	3 3/8	4 1/8	1/2	1
2 1/2	3/8	3/8	2.19	3 7/8	4 5/8	1/2	1
3 1/4	5/8	7/16	2.76	4 11/16	5 1/2	3/8	1
4	5/8	7/16	3.32	5 7/16	6 1/4	3/8	1
5	5/8	9/16	4.1	6 5/8	7 5/8	3/8	1
6	3/4	9/16	4.88	7 5/8	8 5/8	3/8	1 1/8

## MODEL T2R - REAR FLANGE MOUNT (NFPA MF2)

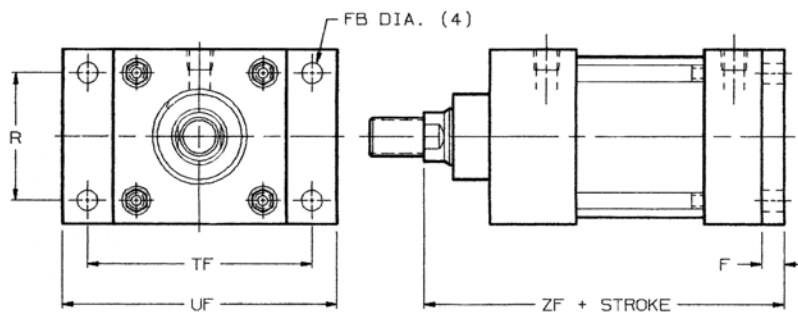

BORE	F	FB	R	TF	UF	ZF
1 1/2	3/8	5/16	1.43	2 3/4	3 3/8	5 3/8
2	3/8	3/8	1.84	3 3/8	4 1/8	5 3/8
2 1/2	3/8	3/8	2.19	3 7/8	4 5/8	5 1/2
3 1/4	5/8	7/16	2.76	4 11/16	5 1/2	6 1/2
4	5/8	7/16	3.32	5 7/16	6 1/4	6 1/2
5	5/8	9/16	4.1	6 5/8	7 5/8	6 3/4
6	3/4	9/16	4.88	7 5/8	8 5/8	7 5/8

## MODEL T2HF - 8" BORE HEAD FLANGE MOUNT (NFPA ME3)

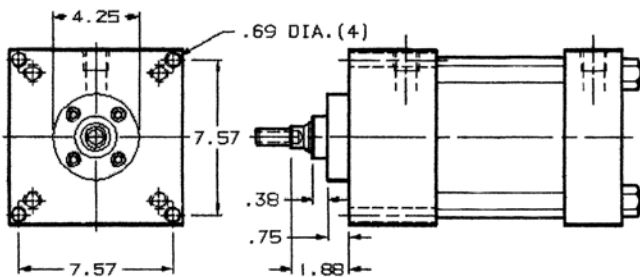

## MODEL T2CF - 8" BORE CAP FLANGE MOUNT (NFPA ME4)

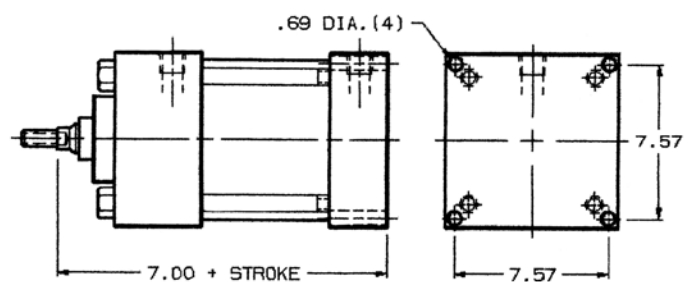

## MODEL T2HF - 10" BORE HEAD FLANGE MOUNT (NFPA ME3)

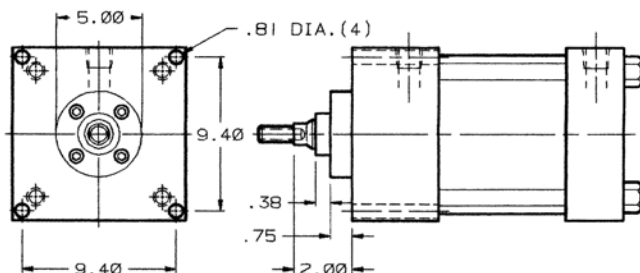

## MODEL T2CF - 10" BORE CAP FLANGE MOUNT (NFPA ME4)

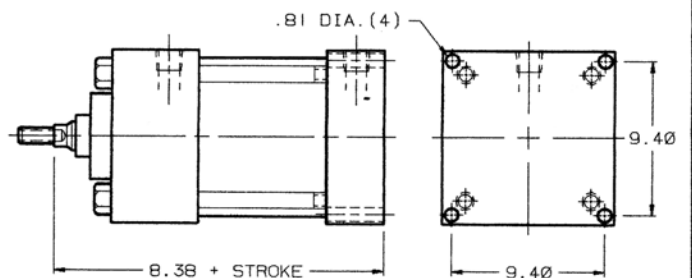

# T2 SERIES CYLINDERS - OVERSIZE ROD DIAMETER

## MODEL T2B - BOTTOM TAP MOUNT (NFPA MS4)

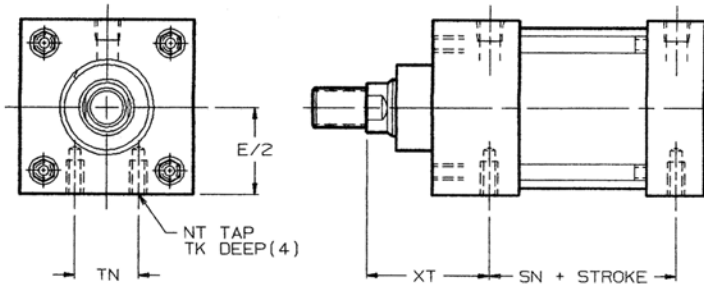

BORE	NT	SN	TK	TN	XT
2	5/16-18	2 1/4	1/2	7/8	2 5/16
2 1/2	3/8-16	2 3/8	5/8	1 1/4	2 5/16
3 1/4	1/2-13	2 5/8	3/4	1 1/2	2 11/16
4	1/2-13	2 5/8	3/4	2 1/16	2 11/16
5	5/8-11	2 7/8	1	2 11/16	2 11/16
6	3/4-10	3 1/8	1 1/8	3 1/4	3 1/16
8	3/4-10	3 1/4	1 1/8	4 1/2	3 1/16

NOT AVAILABLE ON 1 1/2" BORE.

## MODEL T2C - CLEVIS MOUNT (NFPA MP1)

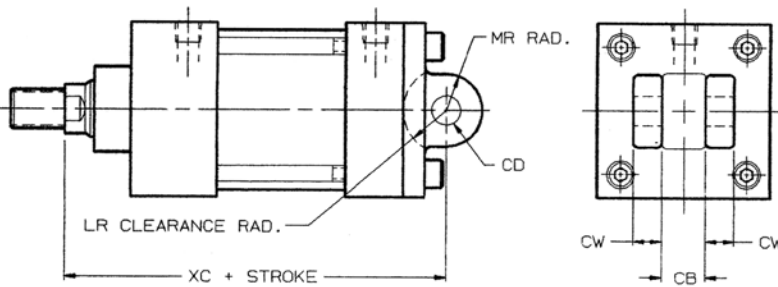

BORE	CB	CD	CW	LR	MR	XC
1 1/2	3/4	1/2	3/8	3/4	5/8	5 3/4
2	3/4	1/2	1/2	3/4	5/8	5 3/4
2 1/2	3/4	1/2	1/2	3/4	5/8	5 7/8
3 1/4	1 1/4	3/4	3/4	1 1/4	7/8	7 1/8
4	1 1/4	3/4	3/4	1 1/4	7/8	7 1/8
5	1 1/4	3/4	3/4	1 1/4	7/8	7 3/8
6	1 1/2	1	1	1 1/2	1 1/8	8 3/8
8	1 1/2	1	3/4	1 1/2	1	8 1/2

## MODEL T2DC - DETACHABLE CLEVIS MOUNT (NFPA MP2)

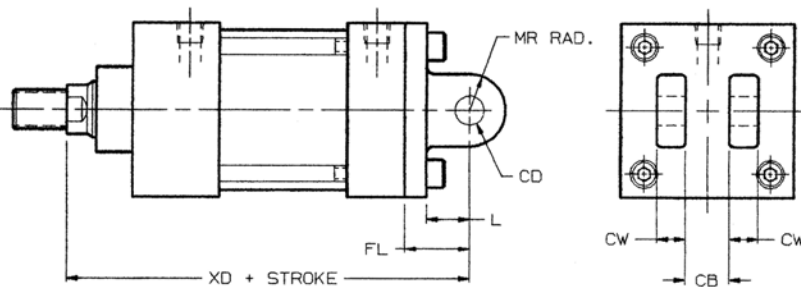

BORE	CB	CD	CW	FL	L	MR	XD
1 1/2	3/4	1/2	3/8	1 1/8	3/4	5/8	6 1/8
2	3/4	1/2	1/2	1 1/8	3/4	5/8	6 1/8
2 1/2	3/4	1/2	1/2	1 1/8	3/4	5/8	6 1/4
3 1/4	1 1/4	3/4	3/4	1 7/8	1 1/4	7/8	7 3/4
4	1 1/4	3/4	3/4	1 7/8	1 1/4	7/8	7 3/4
5	1 1/4	3/4	3/4	1 7/8	1 1/4	7/8	8
6	1 1/2	1	1	2 1/4	1 1/2	1 1/8	9 1/8

## MODEL T2DE - DETACHABLE EYE MOUNT (NFPA MP4)

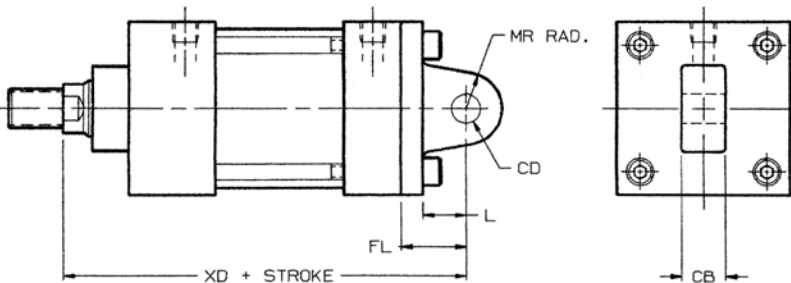

BORE	CB	CD	FL	L	MR	XD
1 1/2	3/4	1/2	1 1/8	3/4	5/8	6 1/8
2	3/4	1/2	1 1/8	3/4	5/8	6 1/8
2 1/2	3/4	1/2	1 1/8	3/4	5/8	6 1/4
3 1/4	1 1/4	3/4	1 7/8	1 1/4	7/8	7 3/4
4	1 1/4	3/4	1 7/8	1 1/4	7/8	7 3/4

# T2 SERIES CYLINDERS - OVERSIZE ROD DIAMETER

## MODEL T2HT - HEAD TRUNNION MOUNT (NFPA MT1)

TRUNNION PINS ARE HARD CHROME PLATED STEEL.  
MAXIMUM PRESSURE RATING 125 PSI.

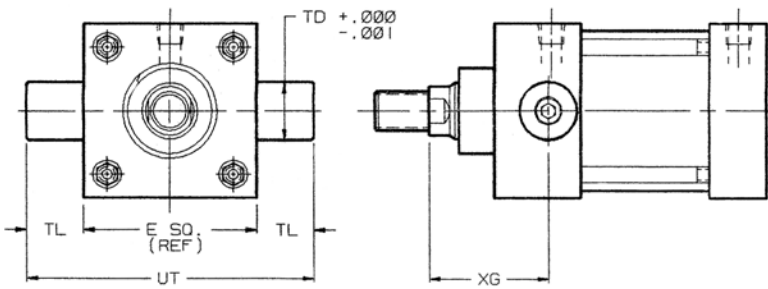

BORE	E	TD	TL	UT	XG
2 1/2	3	1	1	5	2 5/16
3 1/4	3 3/4	1	1	5 3/4	2 11/16
4	4 1/2	1	1	6 1/2	2 11/16
5	5 1/2	1	1	7 1/2	2 11/16
6	6 1/2	1 3/8	1 3/8	9 1/4	3 1/16
8	8 1/2	1 3/8	1 3/8	11 1/4	3 1/16

NOT AVAILABLE ON 1 1/2" AND 2" BORE.

## MODEL T2CT - CAP TRUNNION MOUNT (NFPA MT2)

TRUNNION PINS ARE HARD CHROME PLATED STEEL.  
MAXIMUM PRESSURE RATING 125 PSI.

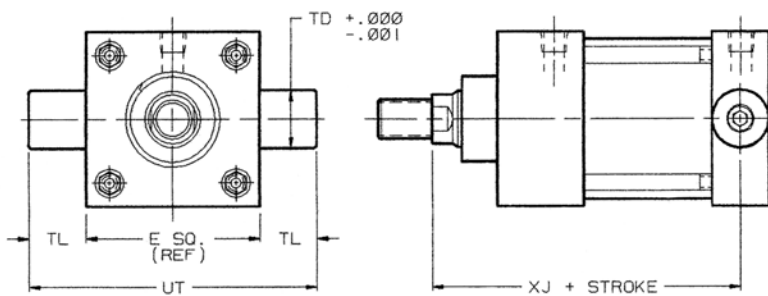

BORE	E	TD	TL	UT	XJ
1 1/2	2	1	1	4	4 1/2
2	2 1/2	1	1	4 1/2	4 1/2
2 1/2	3	1	1	5	4 5/8
3 1/4	3 3/4	1	1	5 3/4	5 1/4
4	4 1/2	1	1	6 1/2	5 1/4
5	5 1/2	1	1	7 1/2	5 1/2
6	6 1/2	1 3/8	1 3/8	9 1/4	6 1/8
8	8 1/2	1 3/8	1 3/8	11 1/4	6 1/4

## MODEL T2IT - INTERMEDIATE TRUNNION MOUNT (NFPA MT4)

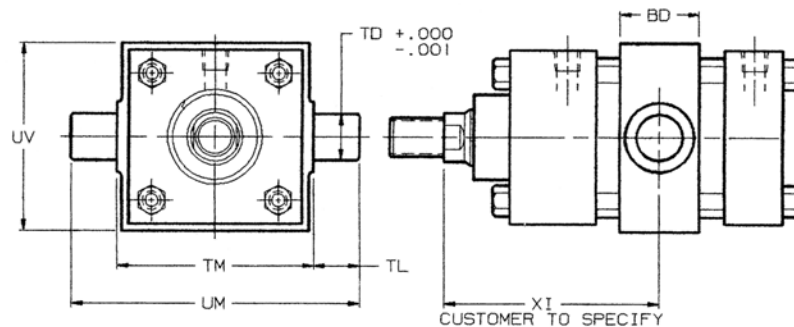

BORE	BD	TD	TL	TM	UM	UV
1 1/2	1 1/4	1	1	2 1/2	4 1/2	2 1/2
2	1 1/2	1	1	3	5	3
2 1/2	1 1/2	1	1	3 1/2	5 1/2	3 1/2
3 1/4	2	1	1	4 1/2	6 1/2	4 1/4
4	2	1	1	5 1/4	7 1/4	5
5	2	1	1	6 1/4	8 1/4	6
6	2 1/2	1 3/8	1 3/8	7 5/8	10 3/8	7

## MODEL T2A - ANGLE MOUNT (NFPA MS1)

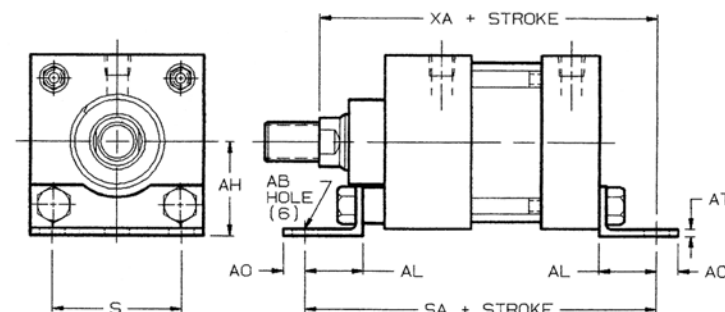

BORE	AB	AH	AL	AO	AT	S	SA	XA
1 1/2	7/16	1 3/16	1	3/8	1/8	1 1/4	6	6
2	7/16	1 7/16	1	3/8	1/8	1 3/4	6	6
2 1/2	7/16	1 5/8	1	3/8	1/8	2 1/4	6 1/8	6 1/8
3 1/4	9/16	1 15/16	1 1/4	1/2	3/16	2 3/4	7 3/8	7 1/8
4	9/16	2 1/4	1 1/4	1/2	3/16	3 1/2	7 3/8	7 1/8
5	11/16	2 3/4	1 3/8	5/8	3/16	4 1/4	7 7/8	7 1/2
6	13/16	3 1/4	1 3/8	5/8	1/4	5 1/4	8 1/2	8 1/4

# T2 SERIES CYLINDERS - OVERSIZE ROD DIAMETER

## MODEL T2L - SIDE LUG MOUNT (NFPA MS2)

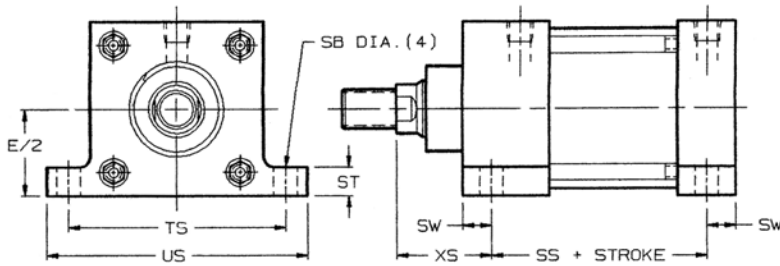

BORE	SB	SS	ST	SW	TS	US	XS
1 1/2	13/32	2 7/8	1/2	3/8	2 3/4	3 1/2	1 3/4
2	13/32	2 7/8	1/2	3/8	3 1/4	4	1 3/4
2 1/2	13/32	3	1/2	3/8	3 3/4	4 1/2	1 3/4
3 1/4	17/32	3 1/4	3/4	1/2	4 3/4	5 3/4	2 1/8
4	17/32	3 1/4	3/4	1/2	5 1/2	6 1/2	2 1/8
5	25/32	3 1/8	1	11/16	6 7/8	8 1/4	2 5/16
6	25/32	3 5/8	1	11/16	7 7/8	9 1/4	2 9/16
8	25/32	3 3/4	1	11/16	9 7/8	11 1/4	2 9/16

## MODEL T2M - EXTENDED TIE ROD MOUNT HEAD END (NFPA MX3)

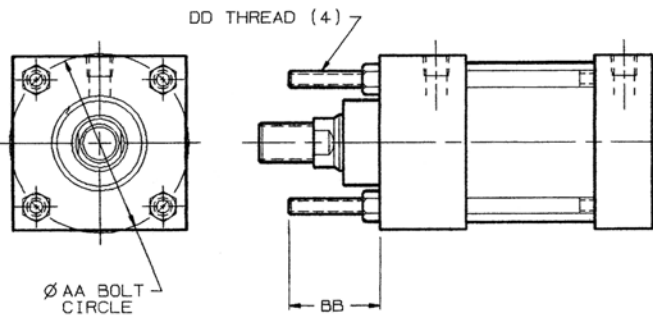

BORE	AA	BB	DD
1 1/2	2.02	1	1/4-28
2	2.60	1 1/8	5/16-24
2 1/2	3.10	1 1/8	5/16-24
3 1/4	3.90	1 3/8	3/8-24
4	4.70	1 3/8	3/8-24
5	5.80	1 13/16	1/2-20
6	6.90	1 13/16	1/2-20
8	9.10	2 5/16	5/8-18

## MODEL T2N - EXTENDED TIE ROD MOUNT CAP END (NFPA MX2)

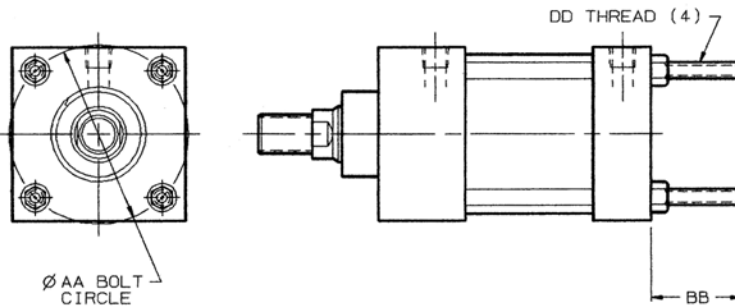

BORE	AA	BB	DD
1 1/2	2.02	1	1/4-28
2	2.60	1 1/8	5/16-24
2 1/2	3.10	1 1/8	5/16-24
3 1/4	3.90	1 3/8	3/8-24
4	4.70	1 3/8	3/8-24
5	5.80	1 13/16	1/2-20
6	6.90	1 13/16	1/2-20
8	9.10	2 5/16	5/8-18

## MODEL T2P - EXTENDED TIE ROD BOTH ENDS (NFPA MX1)

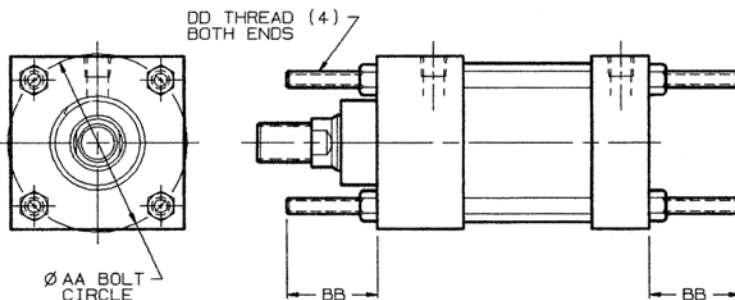

BORE	AA	BB	DD
1 1/2	2.02	1	1/4-28
2	2.60	1 1/8	5/16-24
2 1/2	3.10	1 1/8	5/16-24
3 1/4	3.90	1 3/8	3/8-24
4	4.70	1 3/8	3/8-24
5	5.80	1 13/16	1/2-20
6	6.90	1 13/16	1/2-20
8	9.10	2 5/16	5/8-18

# TECHNICAL INFORMATION

## Rod Diameter selection

Follow these three steps to determine the minimum recommended piston rod diameter for your specific application. First calculate the cylinder thrust using the force chart below. (Thrust = bore area x operating pressure.) Second, choose from the diagrams below the type of mounting you will be using. Calculate the value of "D" with the piston rod fully extended. Now find the value of "D" at the bottom of the rod diameter selector chart. Using a vertical line from this "D" value, follow it up until it intersects with the horizontal line representing the thrust of the cylinder. The area within these intersecting lines determines the minimum piston rod diameter you should use.

## Stop tube selection

Stop tubes are recommended on long stroke cylinders to reduce buckling and extend cylinder life by increasing the length between the rod bearing and piston. To determine if your application requires a stop tube and how long it will be, calculate the value of "D" from the diagrams at the left based on your mounting style. If the value of "D" is less than 40", then a stop tube should not be required. If the value of "D" is over 40", then a 1" stop tube is recommended for every 10" over 40". Note: Stop tubes should be considered for cylinders with "D" being less than 40" if the piston rod is unsupported and side loading is present.

## Force chart

(values in pounds of force generated in push)

BORE	PISTON AREA	PSI									
		40	50	60	80	100	125	150	175	200	250
1 1/2	1.77	71	88	106	142	177	221	266	310	353	442
2	3.14	126	157	189	251	314	392	471	549	628	785
2 1/2	4.91	196	246	295	393	491	614	737	859	982	1227
3 1/4	8.30	322	415	498	664	830	1037	1245	1452	1659	2075
4	12.57	503	629	754	1005	1257	1571	1886	2200	2513	3142
5	19.64	785	982	1178	1571	1964	2455	2946	3437	3928	4910
6	28.27	1131	1414	1696	2262	2827	3534	4241	4947	5654	7068
8	50.27	2011	2514	3016	4022	5027	6284	7541	8797	10054	12567
10	78.54	3142	3927	4712	6283	7854	9818	11781	13745	15708	19635

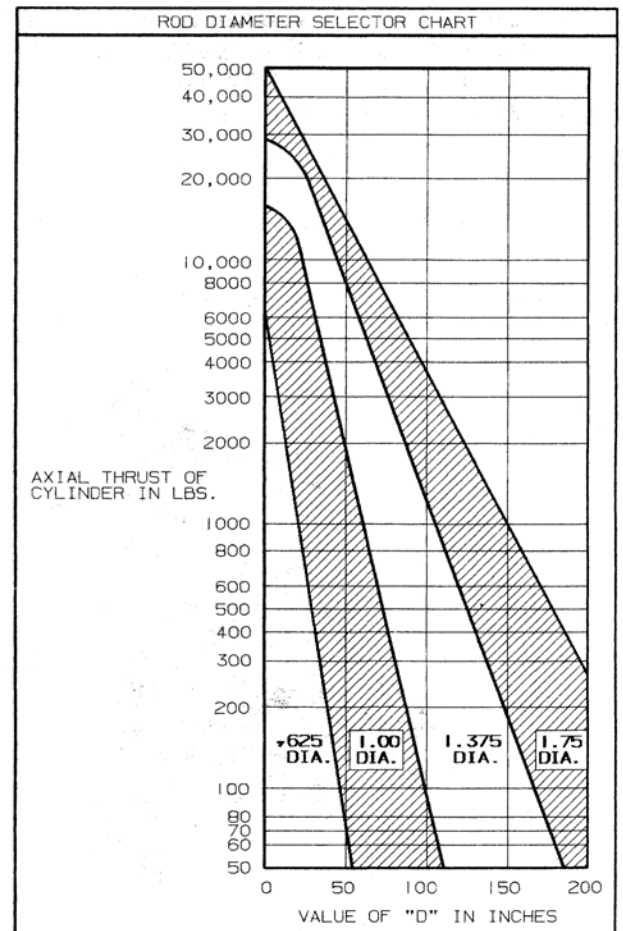
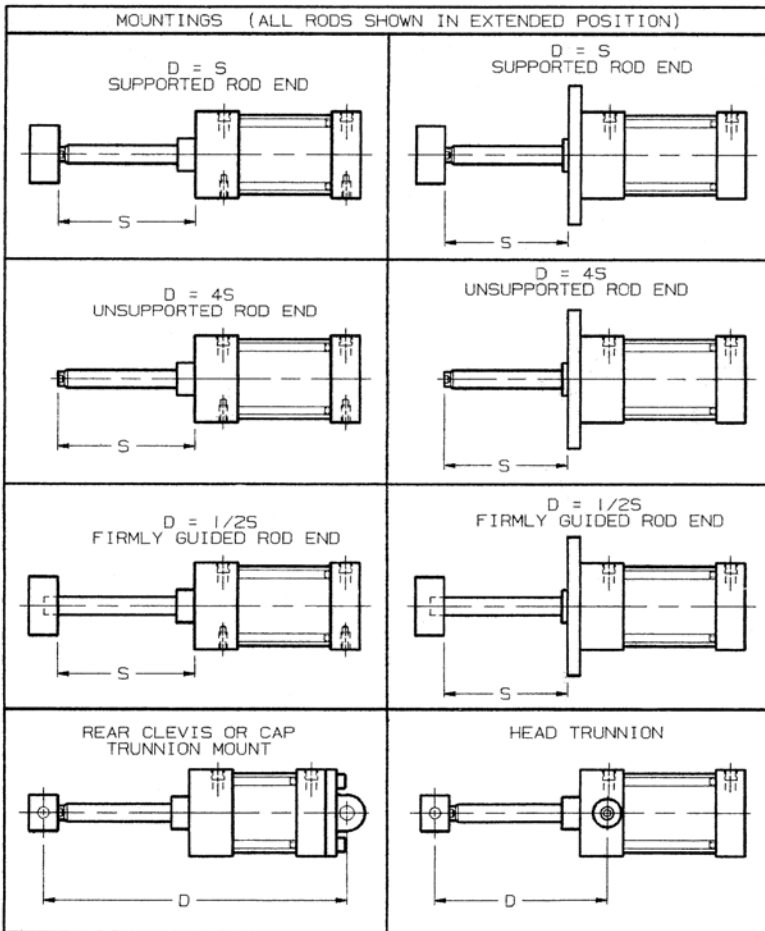



## MAGNETIC PROXIMITY SWITCHES

T-MAC series switches are designed to sense position of piston/rod assembly on T1 and T2 series cylinders. Two reed switches and two hall effect switches are available as standard. These switches mount easily to the tie rods with a unique clamp that allows it to be positioned anywhere along the tie rod giving you infinite position capabilities. Multiple switches can be mounted for sequencing. All switches have a LED indicator light which illuminates when the switch circuit is closed by the presence of a magnet. Optional switches with varying specifications also available. Please consult factory.

### SWITCH SPECIFICATIONS

PART NO.	DESCRIPTION	FUNCTION	SWITCHING VOLTAGE	SWITCHING CURRENT	SWITCHING POWER	SWITCHING SPEED	VOLTAGE DROP
S1-04-9	REED, MOV, 2 WIRE	NORMALLY OPEN-SPST	5-240VDC/VAC 50 / 60 Hz	1 AMP. MAX. .005 AMP MIN.	30 WATTS MAX.	0.6 MS OPERATE 0.05MS RELEASE	3 VOLTS
S2-24-9	REED, MOV 2 WIRE	NORMALLY OPEN TRIAC OUTPUT	24-240VAC 50 / 60 Hz	4 AMP MAX. 50 AMP INRUSH .005 AMP MIN.	100 WATTS MAX.	0.6MS OPERATE 0.05 RELEASE	1 VOLT
S3-31-9	HALL EFFECT, REED MAGNET, SOURCING - 3 WIRE	NORMALLY OPEN PNP OUTPUT	6-24VDC	1 AMP MAX.	24 WATTS MAX.	1.5 MICROSEC. OPERATE 0.5 MICROSEC. RELEASE	0.5 VOLTS
S4-32-9	HALL EFFECT, REED MAGNET, SINKING - 3 WIRE	NORMALLY OPEN NPN OUTPUT	6-24VDC	1 AMP MAX.	24 WATTS MAX.	1.5 MICROSEC. OPERATE 0.5 MICROSEC. RELEASE	0.5 VOLTS

#### Switch Technical Data

Temperature Range - minus 20 degrees F to plus 175 degrees F.

Shock - reed switch only, 30G max. (11 msec.). Not applicable for hall effect switches.

Vibration - reed switch only, 20G max. (10-55 Hz). Not applicable for hall effect switches.

Magnet sensitivity - 85 gauss parallel.

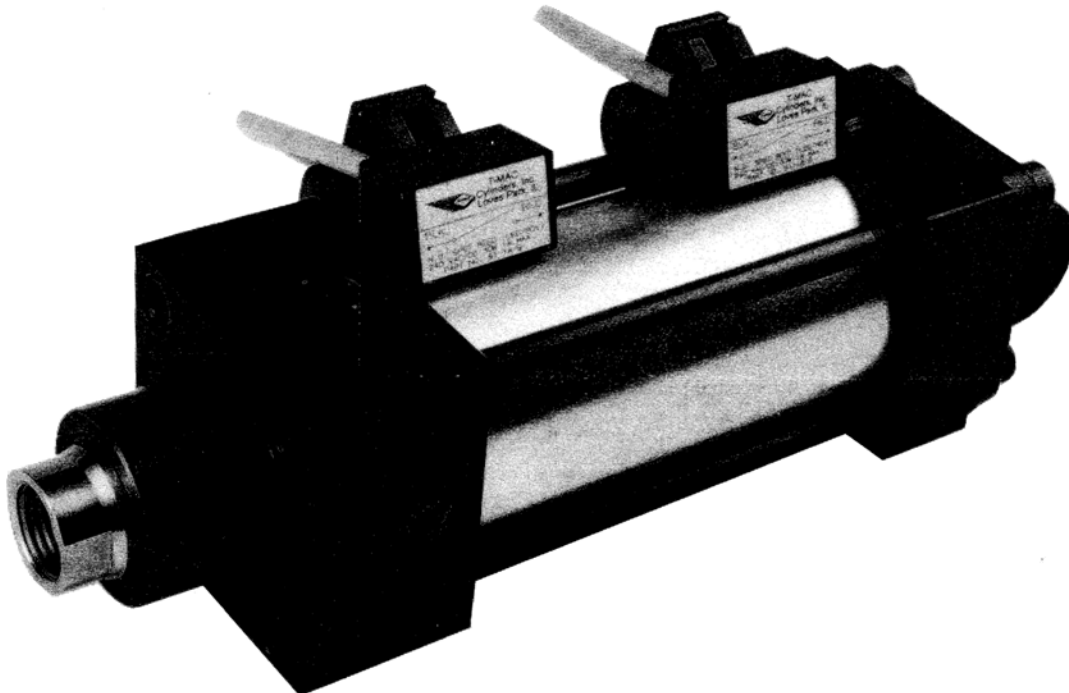

## STANDARD TERMS OF SALE

- 1. Payment.** Subject to credit approval. Payment shall be made by buyer net 30 days from the date of delivery of merchandise purchased herein. Payment made post 30 days shall incur interest at the maximum rate permitted by law for each month or portion thereof that Buyer is late in making such payment. Payment shall not prejudice claims on account of omissions or shortage in shipment, but no such claim will be allowed unless made within 30 days after receipt of Buyer.
- 2. Delivery.** Unless otherwise specified, delivery shall be F.O.B. Seller's plant. Risk of loss shall pass to Buyer upon Seller's delivery to a carrier. Seller shall not be liable for any delays in or failures of delivery due to acts of God or public authority, labor disputes, accidents, fires, floods, extreme weather conditions, failures of and delays by carriers, shortages of materials, delays of a supplier due to causes beyond its control, or any other cause beyond the control of the Seller. Seller shall notify Buyer of any such delays as soon as it becomes apparent. In no event shall Seller be liable for consequential damage arising from delays or failure of delivery. Buyer's requested delivery date shall be approximate and subject to Seller's approval and acceptance.
- 3. Packaging.** All goods shall be packed in containers for protection in shipment. No special packing or crating shall be made unless specifically listed as an additional charge on Seller's quotation or acceptance of Buyer's order.
- 4. Warranty.** All goods sold hereunder are warranted to be free from defects in material and workmanship for a period of 24 months from date of shipment from Seller's plant. These express warranties are in lieu of and exclude all other warranties, express or implied. Seller's sole obligation under these warranties shall be to issue credit, repair, or replace any item or part thereof which is provided to be other than is warranted; no allowance shall be made for any labor charges of Buyer for replacement of parts, adjustment or repairs, or any other work, unless such charges are authorized in advance by Seller. If goods are claimed to be defective in material and/or workmanship, Seller upon notice by Buyer will issue shipping instructions for return of defective product with shipping costs prepaid by Buyer. These warranties shall not extend to any goods or parts thereof which have been subjected to misuse or neglect, damage by accident, rendered defective by reason of improper installation, or by misapplied applications. All design criteria for the use of Seller's products on Buyer's equipment is the sole responsibility of the Buyer.
- 5. Cancellations, changes, or rescheduling.** Buyer may request changes be made in the specifications relating to any goods, quantities and/or schedule dates, or cancellation of goods in part or hole, however, no such requested change shall become part of the contract between Seller and Buyer unless accepted by Seller in a written amendment to this Agreement. If necessary, a equitable adjustment, upward or downward, shall be made in price in so far as warranted.
- 6. Buyer's property.** Any designs, drawings, material, patterns, tools, or equipment furnished by Buyer, or any special tools made or acquired for the Buyer by the Seller which becomes Buyer's property, shall be used only in the production of the goods called for herein and not otherwise, unless by Buyer's written consent. Seller shall not be responsible for any loss or damage to such property while in Seller's possession.
- 7. Special tooling.** A tooling charge may be imposed for special tooling, including but not limited to, fixtures, molds, patterns, or dies. Such tooling shall remain Seller's property notwithstanding payment of any charges by Buyer. Seller may discard obsolete special tooling in its possession at any time, providing two years have passed without Buyer placing an order for such mentioned merchandise.
- 8. Taxes.** Unless otherwise specified on the face hereof, all charges and prices are exclusive of sales, excise, property, use, occupational or like taxes which may be imposed by any taxing authority upon the sale or delivery of the goods sold hereunder. If any such taxes must be paid by Seller, the amount thereof will be in addition to the amount of the goods sold. Buyer agrees to pay all such taxes upon receipt of its invoice. If not collected at time of payment of sales price, Buyer will hold Seller harmless.
- 9. Restocking policy.** Merchandise that is returned must be accompanied by pre-approved Return Goods Authorization (RGA). Return authorizations shall be approved by Seller. When goods are received, inspection of such goods will be performed to determine restocking charges. Goods returned without authorization will be returned to Buyer at Buyer's expense.